



**Linear Bar Grilles**

4900 Series

# Linear Bar Grilles

## 4900 Series

The Model Series 4900 Linear Bar Grilles have been specially designed to provide the precision quality appearance required for architectural excellence with crisply sculptured styling, careful workmanship and effective air distribution.

The Series 4900 Linear Bar Grilles are designed for heating and cooling applications, supply and return.

The grilles are manufactured with precision mitred corners to maximise quality.

- Fixed Bars
- Aluminium Construction

### Models:

13mm Bar Spacing

49-240 ■ 6mm Bars ■ 0° Deflection ■ Pencil-Proof

49-241 ■ 6mm Bars ■ 15° Deflection ■ Pencil-Proof

49-243 ■ 6mm Bars ■ 30° Deflection ■ Pencil-Proof

49-280 ■ 3mm Bars ■ 0° Deflection

49-281 ■ 3mm Bars ■ 15° Deflection

6mm Bar Spacing

49-480 ■ 3mm Bars ■ 0° Deflection

49-481 ■ 3mm Bars ■ 15° Deflection

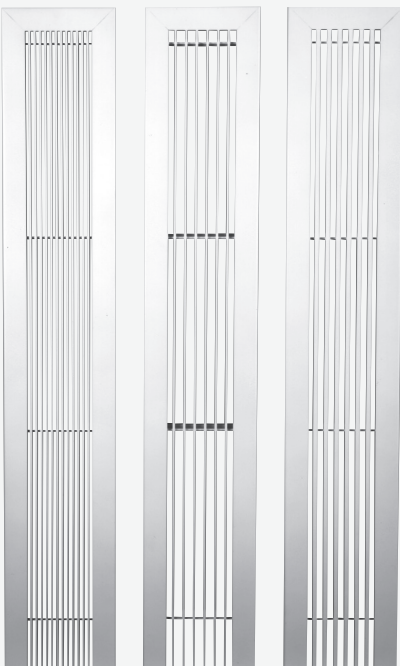



- Features:**
- Deflection bars are fixed and are parallel to the long dimension.
  - Available in 7 core styles and a variety of frame and sub-frame options.
  - Diffusers are supplied in lengths of up to 1800mm in a single section.
  - Standard incremental units of length are 300, 600, 900, 1200, 1500 and 1800. However, the 4900 Series is available in any nominal length to suit engineering and architectural requirements.
  - Ideal for continuous length applications
  - Multiple-sections are supplied with alignment strips on the frame and sub-frame to provide superior, positive site alignment.
  - End caps are staked and mitred for a superior quality appearance.
  - Standard duty models are available for ceiling, wall or sill installations. Heavy duty models are designed specifically for use in floor installations.

- Options:**
- Aluminium opposed blade damper (add suffix 'OA').
  - MC Mitred Corner Sections.
  - BO Blanking Plates
  - Material: Extruded aluminium.
  - Finish: White polyester powder finish RAL 9010 semi-gloss. Other finishes are available.

# Available Frame Types and Dimensional Data

## Type A

25mm border

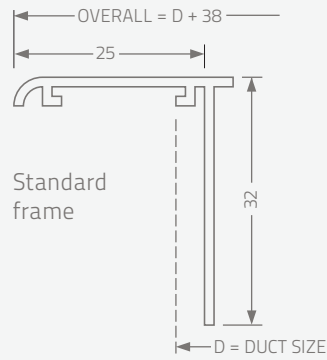

## Type B

19mm reduced border

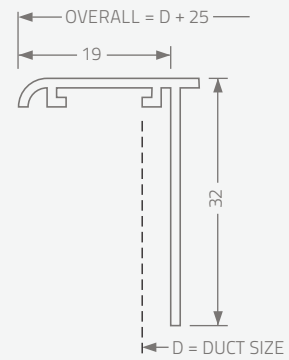

## Type D

25mm border

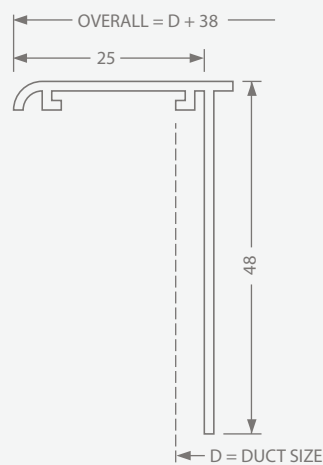

## Heavy duty mounting frames for floor installations

## Type F

25mm border flange

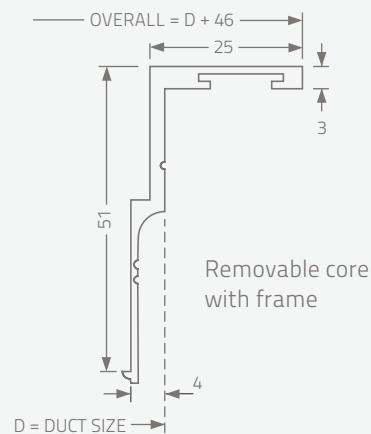

## Type G

No flange flush mounting

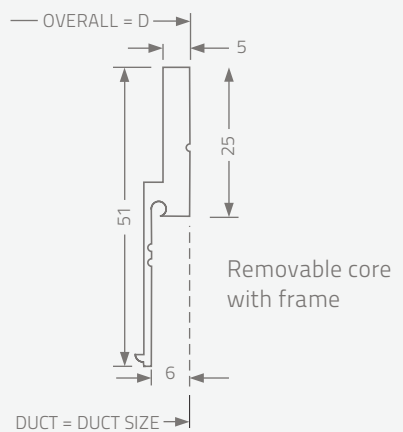



# Available Core Styles

## Pencil Proof

13mm Spacing, 6mm Bars  
Model 49-240 ■ 0° Deflection

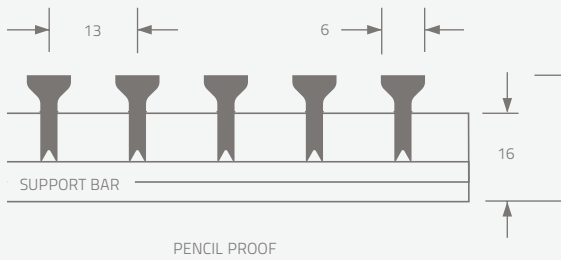

## Pencil Proof

13mm Spacing, 6mm Bars  
Model 49-241 ■ 15° Deflection

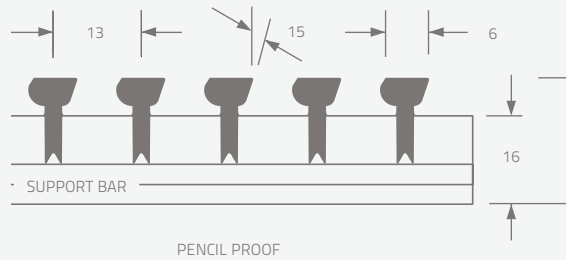

## Pencil Proof

13mm Spacing, 6mm Bars  
Model 49-243 ■ 30° Deflection

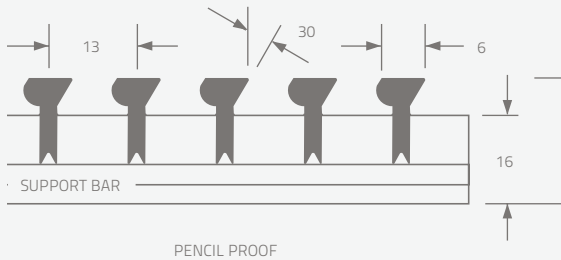

## Pencil Proof

13mm Spacing, 3mm Bars  
Model 49-280 ■ 0° Deflection

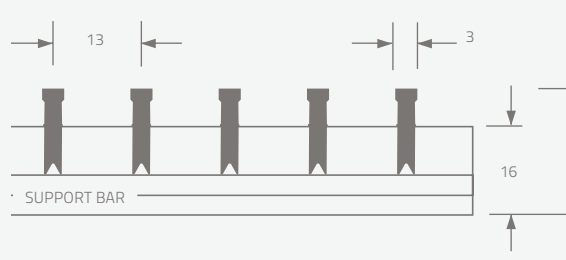

## Pencil Proof

13mm Spacing, 3mm Bars  
Model 49-281 ■ 15° Deflection

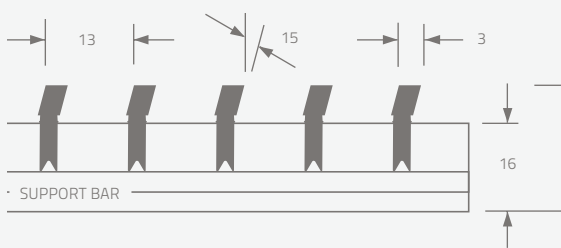

## Heel Proof

6mm Spacing, 3mm Bars  
Model 49-480 ■ 0° Deflection

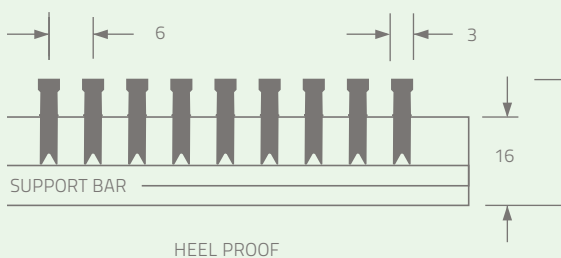

## Heel Proof

6mm Spacing, 3mm Bars  
Model 49-481 ■ 15° Deflection

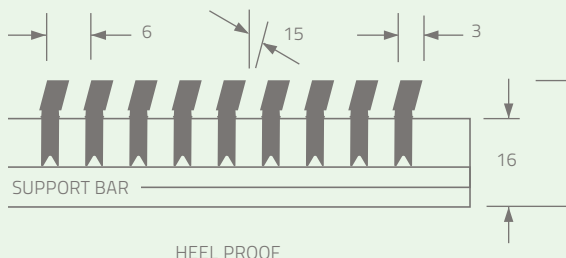

# Overall Length and Width Dimensional Data

## Frame Types

Type	N	O
A	D - 13mm	D + 38mm
B	D - 13mm	D + 25mm
D	D - 13mm	D + 38mm
E	D - 13mm	D + 13mm
F	D	D + 46mm
G	D	D

Dimensions are for length or width.

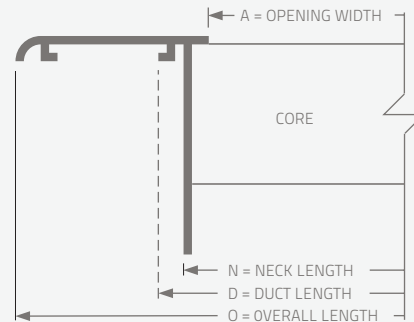

## Standard Widths and Core Dimensional Data

Duct Width D	6mm Spacing	
	Opening Width A	Number of Bars
38	19	2
50	31	4
65	45	6
75	56	8
90	71	10
100	81	12
125	106	16
150	131	20

Duct Width D	13mm Spacing	
	Opening Width A	Number of Bars
38	19	1
50	31	2
65	45	3
75	56	4
90	71	5
100	81	6
125	106	8
150	131	10

For frames types F and G increase the number of bars by two. Dimensions are in mm.

## Cross-Bar Spacing

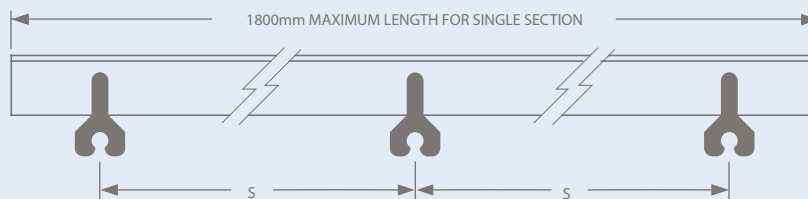

Standard Core: S = 300mm maximum support bar spacing. Frame Types A, B, and D.  
 Optional HC Heavy Duty Core: S = 200mm maximum.  
 Standard for floor models with frame types F and G, which also include secondary reinforcing support bars.





# Typical Frame/Core Assemblies

## Core with Frame

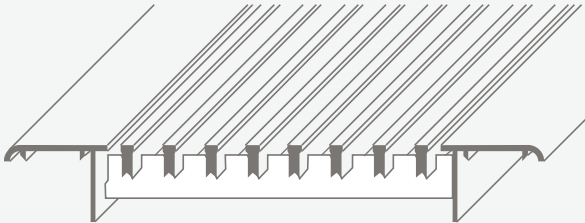

Type A Frame

## Core only

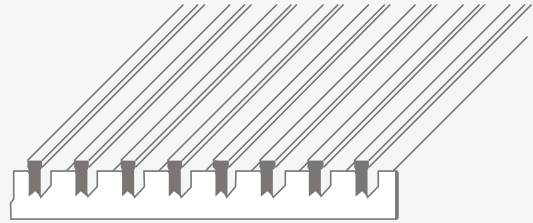

## Core with Heavy Duty Mounting Frame

Additional  
Cross-Bar  
Support

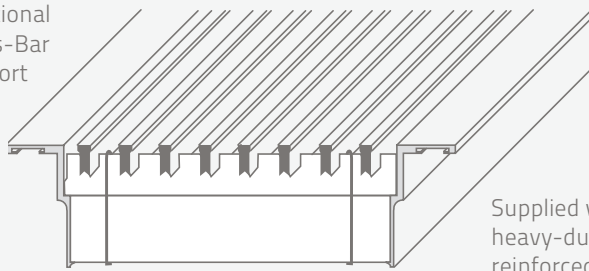

Supplied with  
heavy-duty  
reinforced core  
and core clips

Type F Heavy Duty Mounting Frame

## Fastenings

Type A ■ Countersunk Screw Holes

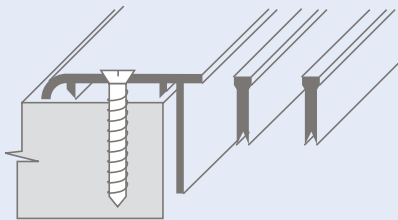

For ceiling, side wall, sill or floor.  
Frame Types - A, B, D, F.

Type B ■ Friction Spring Clip

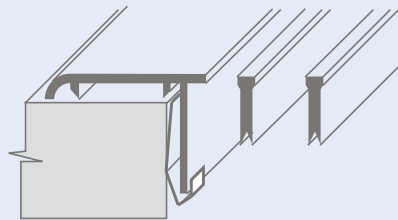

For sill installations.  
Frame Types - A, B, E, F, G.

Type C ■ Concealed Mounting

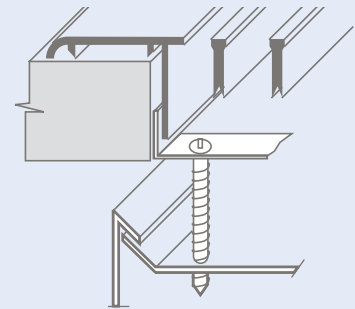

For ceiling, side wall, sill or floor.  
Frame Types - A, B, D.  
Not recommended for use with  
cores with 6mm bar spacing.

# Options and Accessories

## Type DV Directional Vanes

For all available widths.

Fully adjustable extruded aluminium blades on 19mm centres perpendicular to length.

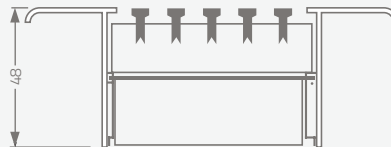

Requires Frame Type D (deep stack), F or G

## Opposed Blade Damper

For linear bar grilles with a nominal duct width of 64mm and wider.  
Access Doors

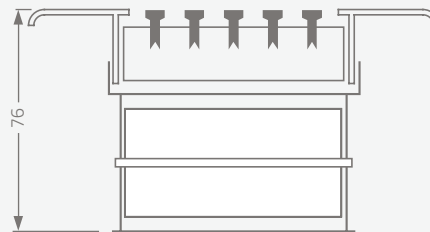

## Type BO Steel Blank-Off

For all available widths. Supplied in 1829mm lengths for site cutting.  
Steel, painted black.

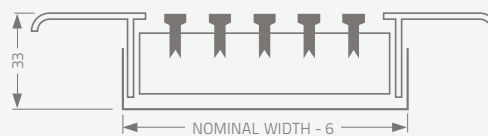

## Alignment Strips

Supplied as standard on multiple-section assemblies to provide positive and accurate site alignment, except frame G which uses alignment pins.

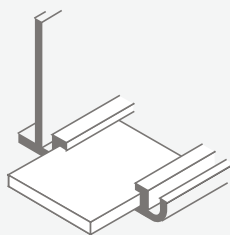





# Dimensional Data

## Mitred Corner Sections

49-240MC  
49-241MC  
49-243MC  
49-280MC

49-281MC  
49-480MC  
49-481MC

### Floor, Ceiling or Sill

- Type O   ▪ 0° deflection
- Type A   ▪ Deflection inside
- Type B   ▪ Deflection outside

Factory welded with precision to match and align with the associated straight leg.

Standard mitred corner section for floor, ceiling or wall is 90 degrees. Other angles are available.

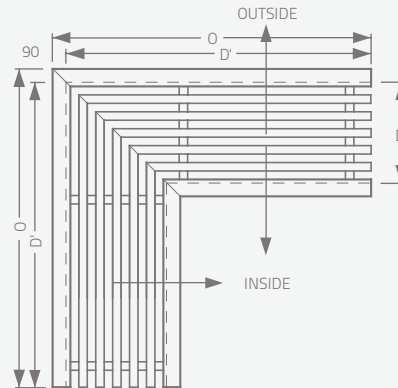

### 90° Mitred Corner Dimension 'O'

Duct Width D	Duct Length D	Frame Type					
		A, D	B	C	E	F	G
38 – 100	300	319	313	327	306	320	300
101 – 300	450	468	462	605	598	602	449

## Continuous Run Dimensions

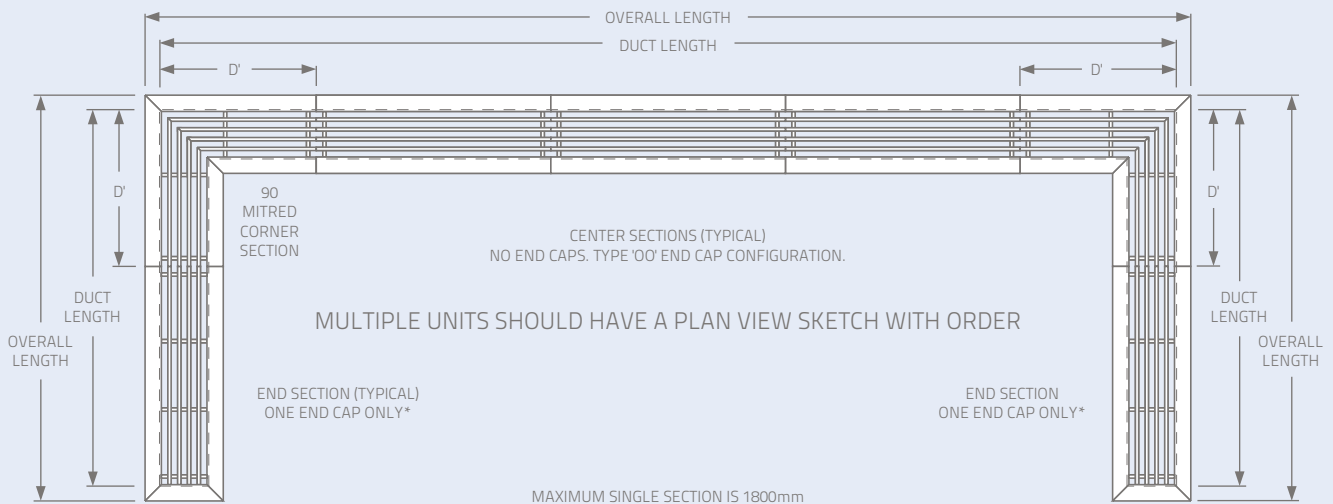

\*End sections with single end caps and deflecting cores must be specified and ordered with the desired core deflection direction.

End cap configurations (mitred end cap one end and open opposite end):

Type 'MO' = 0° deflection

Type 'MU' = (15° or 30°)



Type 'MD' = (15° or 30°)

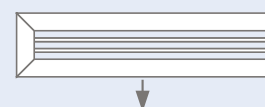

# Typical Opening Preparations

Ceiling 1  
 Frame Types A, B, D, or E

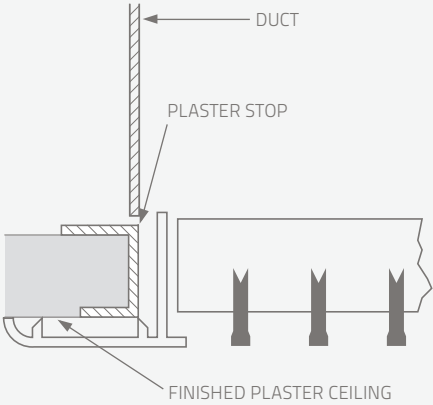

Floor or Sill 1  
 Frame Type F

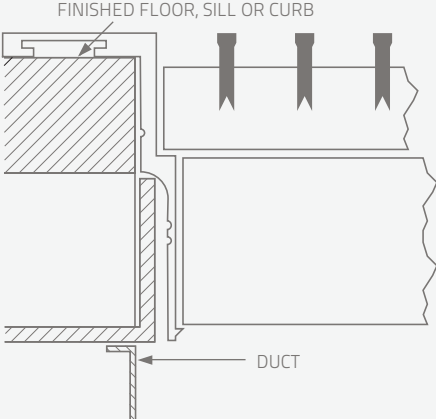

Floor or Sill 2  
 Frame Type G

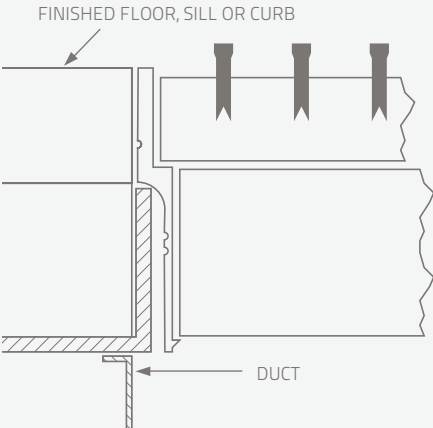

Raised Sill 1  
 Core Only

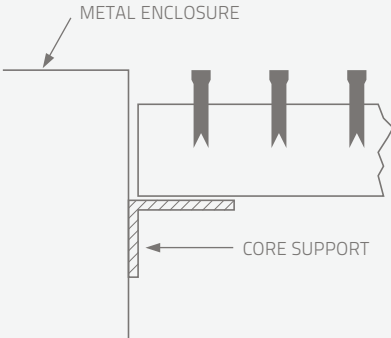

Raised Sill 2  
 Frame Types A, B or D

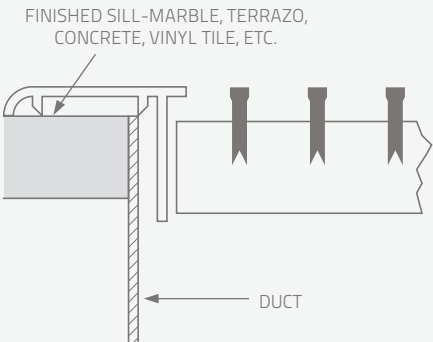

Side Wall 1  
 Frame Types A, B or D

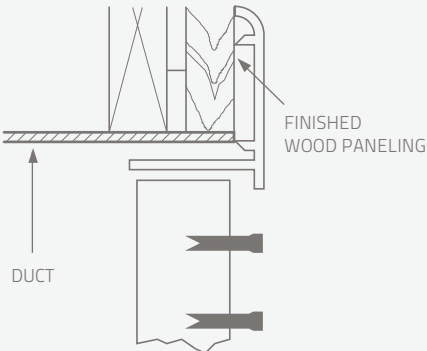



# How To Specify or To Order

## Extruded Aluminium Linear Bar Grilles ■ Model Series 4900

**49 - 2 4 0 - 0 - 1500 x 100 - B - AW - C - MM - AD**

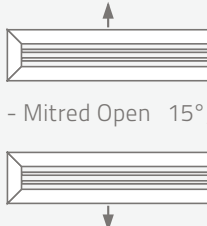
<p><b>Model</b></p> <ul style="list-style-type: none"> <li>- Linear Bar Grille</li> </ul> <p><b>Bar Spacing</b></p> <ul style="list-style-type: none"> <li>- 13mm                    2</li> <li>- 6mm                      4</li> </ul> <p><b>Bar Width</b></p> <ul style="list-style-type: none"> <li>- 6mm                      4</li> <li>- 3mm                      8</li> </ul> <p><b>Bar Deflection</b></p> <ul style="list-style-type: none"> <li>- 0°                         0</li> <li>- 15°                      1</li> <li>- 30°                      3</li> </ul> <p><b>Damper</b></p> <ul style="list-style-type: none"> <li>- No Damper (default)    —</li> <li>- With Damper            OA</li> </ul> <p><b>Length</b> mm</p> <p><b>Width</b> mm</p> <p><b>Frame or Frame/Sub-Frame Combination</b></p> <ul style="list-style-type: none"> <li>- 25mm                     A</li> <li>- 19mm                     B</li> <li>- 25mm with deep neck   D</li> <li>- 25mm Heavy duty      F</li> <li>- No Flange Heavy duty   G</li> <li>- Core Only                CO</li> </ul>	<p><b>Accessories</b></p> <ul style="list-style-type: none"> <li>- Blank-Offs                BO</li> <li>- Access Door              AD</li> <li>- Heavy duty core         HC</li> <li>- Deflector Vanes         DV</li> </ul> <p><b>End Cap Configuration</b></p> <ul style="list-style-type: none"> <li>- Mitred Mitred (default) MM</li> <li>- Open Open                OO</li> <li>- Mitred Open 0°          MO</li> <li>- Mitred Open 15°, 30°   MU</li> </ul> <div style="text-align: center;">  <p>- Mitred Open 15°, 30°    MD</p> </div> <p><b>Fastening</b></p> <ul style="list-style-type: none"> <li>- None (default)            N</li> <li>- Screw Holes              A</li> <li>- Spring Clips              B</li> <li>- Concealed Mounting     C</li> </ul> <p><b>Finish</b></p> <ul style="list-style-type: none"> <li>- RAL 9010 semi gloss white AW</li> <li>- Aluminium                AL</li> <li>- Mill Finish                MI</li> <li>- Special                     SP</li> </ul>
--	---

(Show complete Model Number and Size, unless "Default" is desired)

**Notes:**

1. To use more than one "Accessory", list the items in order and specify description.
2. It is helpful to include a sketch for multiple units with mitred corners.

# Performance Data

## Model 49-240 ■ 13mm Spacing ■ 6mm Bars ■ 0° Deflection

Free Area (m <sup>2</sup> ) per Metre Length	Nominal Duct Width (mm)	Pressure Drop (Pa)	2	5	10	15	22	30	39	49	61
0.01	50	Flowrate per Length (l/s/m)	28	42	56	70	84	98	111	125	139
		NC Level	—	—	12	18	23	29	33	36	39
		Throw (m) Sill or Floor Side Wall	0.3 - 0.3 1.5 - 2.1	1.2 - 1.2 2.7 - 3.7	2.1 - 2.1 3.4 - 4.9	2.7 - 3.0 4.3 - 6.1	3.4 - 4.0 5.2 - 7.0	4.3 - 4.9 5.8 - 7.9	4.9 - 5.5 6.4 - 8.5	5.2 - 6.1 6.7 - 9.1	5.8 - 6.4 7.6 - 10.1
0.03	75	Flowrate per Length (l/s/m)	54	82	108	136	164	190	218	245	273
		NC Level	—	—	15	21	27	32	36	39	42
		Throw (m) Sill or Floor Side Wall	0.6 - 0.6 2.1 - 3.0	2.1 - 2.1 3.4 - 4.6	3.0 - 3.4 4.3 - 5.8	4.0 - 4.6 5.2 - 7.0	4.9 - 5.5 6.4 - 8.2	5.8 - 6.4 7.3 - 9.4	6.7 - 7.3 8.2 - 10.4	7.3 - 7.6 9.4 - 11.9	7.9 - 8.2 10.4 - 12.5
0.04	100	Flowrate per Length (l/s/m)	82	124	164	206	248	288	330	370	412
		NC Level	—	—	17	23	29	34	38	41	44
		Throw (m) Sill or Floor Side Wall	0.9 - 0.9 2.3 - 3.4	2.7 - 2.7 4.0 - 5.2	4.0 - 4.0 5.2 - 6.4	4.9 - 5.2 6.4 - 7.9	6.1 - 6.4 7.6 - 9.1	7.0 - 7.3 8.5 - 10.4	7.6 - 7.9 9.1 - 11.3	8.5 - 8.5 10.6 - 12.5	9.4 - 9.4 11.6 - 13.7
0.05	125	Flowrate per Length (l/s/m)	110	164	220	274	328	384	438	492	548
		NC Level	—	10	18	24	30	35	39	42	45
		Throw (m) Sill or Floor Side Wall	1.2 - 1.2 3.0 - 4.0	3.0 - 3.0 4.3 - 5.5	4.6 - 4.6 5.8 - 7.0	5.5 - 5.5 6.7 - 8.2	6.7 - 7.0 8.2 - 9.8	7.6 - 7.6 9.4 - 11.3	8.2 - 8.5 10.1 - 11.9	9.1 - 9.1 11.3 - 13.1	10.4 - 10.4 12.5 - 14.3
0.07	150	Flowrate per Length (l/s/m)	138	206	276	344	412	480	550	619	687
		NC Level	—	11	20	25	31	36	40	43	46
		Throw (m) Sill or Floor Side Wall	1.5 - 1.5 3.4 - 4.3	3.0 - 3.0 4.8 - 6.1	4.6 - 4.6 6.1 - 7.3	5.8 - 5.8 7.3 - 8.8	7.0 - 7.0 8.8 - 10.4	7.6 - 7.6 10.1 - 11.9	8.8 - 8.8 10.6 - 12.2	9.4 - 9.4 12.2 - 13.7	11.0 - 11.0 13.4 - 14.9

## Model 49-243 ■ 13mm Spacing ■ 6mm Bars ■ 30° Deflection

Free Area (m <sup>2</sup> ) per Metre Length	Nominal Duct Width (mm)	Pressure Drop (Pa)	3	6	12	18	26	35	47	59	73
0.01	50	Flowrate per Length (l/s/m)	29	45	59	74	90	104	119	133	149
		NC Level	—	12	20	27	32	37	41	44	47
		Throw (m) Sill or Floor Side Wall	0.3 - 0.3 1.5 - 2.1	1.2 - 1.2 2.4 - 3.7	2.1 - 2.1 3.4 - 4.9	2.7 - 3.0 4.3 - 6.1	3.7 - 4.0 5.2 - 7.3	4.3 - 4.6 5.8 - 7.9	4.9 - 5.5 6.7 - 8.8	5.5 - 6.1 7.0 - 9.4	5.8 - 6.7 7.6 - 10.4
0.03	75	Flowrate per Length (l/s/m)	53	81	107	133	159	186	214	240	266
		NC Level	—	12	20	27	32	37	41	44	47
		Throw (m) Sill or Floor Side Wall	0.6 - 0.6 1.8 - 2.7	1.8 - 1.8 3.4 - 4.6	3.0 - 3.4 4.3 - 5.8	4.0 - 4.3 5.5 - 7.0	4.9 - 5.5 6.4 - 8.2	5.8 - 6.1 7.3 - 9.4	6.4 - 7.0 8.5 - 10.7	7.3 - 7.6 9.1 - 11.6	7.6 - 7.6 10.4 - 12.5
0.04	100	Flowrate per Length (l/s/m)	79	118	158	197	235	276	314	353	393
		NC Level	—	13	21	29	34	39	43	46	49
		Throw (m) Sill or Floor Side Wall	0.9 - 0.9 2.7 - 3.7	2.7 - 2.7 4.0 - 5.2	4.0 - 4.0 5.2 - 6.7	4.9 - 5.2 6.1 - 7.6	6.1 - 6.4 7.3 - 9.1	6.7 - 7.0 8.5 - 10.4	7.6 - 7.9 9.4 - 11.6	8.2 - 8.2 11.0 - 12.5	9.1 - 9.1 11.3 - 13.4
0.05	125	Flowrate per Length (l/s/m)	104	155	207	259	310	362	413	466	517
		NC Level	—	13	21	29	34	39	43	46	49
		Throw (m) Sill or Floor Side Wall	1.2 - 1.2 3.4 - 4.3	3.0 - 3.0 4.6 - 5.8	4.3 - 4.3 5.8 - 7.3	5.5 - 5.5 7.0 - 8.5	6.4 - 6.7 7.9 - 9.8	7.3 - 7.6 9.1 - 11.0	8.2 - 8.5 9.8 - 11.9	9.1 - 9.1 11.0 - 12.8	9.8 - 9.8 11.9 - 14.0
0.06	150	Flowrate per Length (l/s/m)	130	195	260	325	390	455	520	585	650
		NC Level	—	15	23	31	36	41	45	48	51
		Throw (m) Sill or Floor Side Wall	1.5 - 1.5 3.7 - 4.6	3.0 - 3.0 5.2 - 6.4	4.6 - 4.6 6.4 - 7.6	5.8 - 5.8 7.3 - 8.8	7.0 - 7.0 8.8 - 10.4	7.6 - 7.6 9.8 - 11.6	8.5 - 8.8 10.7 - 12.2	9.4 - 9.4 11.6 - 13.1	10.7 - 10.7 12.8 - 14.3

# Performance Data

## Model 49-280 ■ 13mm Spacing ■ 3mm Bars ■ 0° Deflection

Free Area (m <sup>2</sup> ) Per metre Length	Nominal Duct Width (mm)	Pressure Drop (Pa)	2	5	9	14	19	27	35	44	55
0.02	50	Flowrate per Length (l/s/m)	34	51	68	85	102	119	136	153	170
		NC Level	—	—	12	18	23	28	32	35	38
		Throw (m) Sill or Floor Side Wall	0.3 - 0.3 1.5 - 2.1	1.2 - 1.2 2.4 - 3.7	2.1 - 2.1 3.4 - 4.9	2.7 - 3.0 4.3 - 6.1	3.4 - 3.7 5.2 - 7.0	4.3 - 4.9 5.8 - 7.9	4.9 - 5.5 6.4 - 8.5	5.2 - 6.1 6.7 - 9.1	5.8 - 6.4 7.6 - 10.1
0.03	75	Flowrate per Length (l/s/m)	59	90	119	149	178	207	238	268	297
		NC Level	—	—	11	17	22	27	31	34	37
		Throw (m) Sill or Floor Side Wall	0.6 - 0.6 2.1 - 3.0	2.1 - 2.1 3.0 - 4.3	3.0 - 3.4 4.3 - 5.8	4.0 - 4.3 5.2 - 7.0	4.9 - 5.2 6.1 - 7.9	5.8 - 6.1 7.3 - 9.1	6.4 - 7.0 8.2 - 10.4	7.3 - 7.6 9.1 - 11.6	7.6 - 7.9 10.1 - 12.5
0.04	100	Flowrate per Length (l/s/m)	87	129	172	215	259	302	344	387	430
		NC Level	—	—	12	18	23	28	32	35	38
		Throw (m) Sill or Floor Side Wall	0.9 - 0.9 2.4 - 3.4	2.7 - 2.7 4.0 - 5.2	4.0 - 4.0 5.2 - 6.4	4.9 - 5.2 6.1 - 7.6	6.1 - 6.4 7.6 - 9.1	7.0 - 7.3 8.5 - 10.4	7.6 - 7.9 9.1 - 11.3	8.2 - 8.2 10.7 - 12.5	9.1 - 9.1 11.6 - 13.4
0.05	125	Flowrate per Length (l/s/m)	111	166	221	277	333	387	443	499	554
		NC Level	—	—	12	18	23	28	32	35	38
		Throw (m) Sill or Floor Side Wall	1.2 - 1.2 3.0 - 4.0	3.0 - 3.0 4.3 - 5.5	4.3 - 4.3 5.8 - 7.0	5.5 - 5.5 6.7 - 8.2	6.7 - 7.0 8.2 - 9.8	7.3 - 7.3 9.1 - 11.0	8.2 - 8.5 10.1 - 11.9	9.1 - 9.4 11.3 - 13.1	9.8 - 9.8 12.5 - 14.3
0.07	150	Flowrate per Length (l/s/m)	136	206	274	342	410	480	548	616	684
		NC Level	—	—	14	20	24	29	33	36	39
		Throw (m) Sill or Floor Side Wall	1.5 - 1.5 3.7 - 4.6	3.0 - 3.0 4.9 - 6.1	4.6 - 4.6 6.1 - 7.3	5.5 - 5.5 7.3 - 8.8	7.0 - 7.0 8.8 - 10.4	7.6 - 7.6 10.1 - 11.9	8.5 - 8.5 10.7 - 12.2	9.4 - 9.4 12.2 - 13.7	9.8 - 9.8 13.4 - 14.9

## Model 49-281 ■ 13mm Spacing ■ 3mm Bars ■ 15° Deflection

Free Area (m <sup>2</sup> ) Per Metre Length	Nominal Duct Width (mm)	Pressure Drop (Pa)	2	5	9	14	19	27	35	44	55
0.02	50	Flowrate per Length (l/s/m)	34	53	70	87	104	121	139	156	173
		NC Level	—	12	20	26	31	36	40	44	47
		Throw (m) Sill or Floor Side Wall	0.3 - 0.3 1.5 - 2.1	1.2 - 1.2 2.4 - 3.7	2.1 - 2.1 3.4 - 4.9	2.7 - 3.0 4.3 - 6.1	3.7 - 4.0 5.2 - 7.0	4.3 - 4.9 5.5 - 7.6	4.9 - 5.5 6.1 - 8.2	5.2 - 6.1 6.7 - 9.1	5.8 - 6.4 7.9 - 10.4
0.03	75	Flowrate per Length (l/s/m)	57	87	115	144	173	201	231	259	288
		NC Level	—	—	17	23	29	34	38	42	45
		Throw (m) Sill or Floor Side Wall	0.6 - 0.6 1.8 - 2.7	1.8 - 1.8 3.0 - 4.3	3.0 - 3.0 4.0 - 5.5	3.7 - 4.0 5.2 - 6.7	4.9 - 5.2 6.1 - 7.9	5.8 - 6.1 7.3 - 9.1	6.4 - 7.0 7.9 - 10.1	7.0 - 7.3 9.1 - 11.3	7.6 - 7.6 9.8 - 11.9
0.04	100	Flowrate per Length (l/s/m)	82	124	164	206	248	288	328	370	412
		NC Level	—	10	18	24	30	35	39	43	46
		Throw (m) Sill or Floor Side Wall	0.9 - 0.9 2.4 - 3.4	2.4 - 2.7 3.7 - 4.9	4.0 - 4.0 5.2 - 6.4	4.6 - 4.9 5.8 - 6.4	5.8 - 6.1 7.3 - 8.8	6.7 - 7.0 8.2 - 10.1	7.3 - 7.6 9.1 - 11.0	7.9 - 8.2 10.1 - 11.9	9.1 - 9.1 11.3 - 13.1
0.05	125	Flowrate per Length (l/s/m)	107	161	214	268	322	375	429	483	536
		NC Level	—	10	18	24	30	35	39	43	46
		Throw (m) Sill or Floor Side Wall	1.2 - 1.2 3.0 - 4.0	2.7 - 2.7 4.3 - 5.5	4.3 - 4.3 5.8 - 7.0	5.2 - 5.2 6.4 - 7.9	6.4 - 6.7 7.6 - 9.4	7.3 - 7.3 8.8 - 10.7	7.9 - 8.2 10.1 - 11.6	8.8 - 8.8 10.7 - 12.5	9.8 - 9.8 11.9 - 13.7
0.06	150	Flowrate per Length (l/s/m)	132	197	263	328	393	458	525	591	657
		NC Level	—	10	18	24	30	35	39	43	46
		Throw (m) Sill or Floor Side Wall	1.5 - 1.5 3.4 - 4.3	3.0 - 3.0 4.9 - 6.1	4.6 - 4.6 6.1 - 7.3	5.5 - 5.5 7.3 - 8.5	7.0 - 7.0 8.2 - 9.8	7.6 - 7.6 9.1 - 11.0	8.5 - 8.5 10.1 - 11.9	9.1 - 9.1 11.3 - 12.8	10.4 - 10.4 12.5 - 14.0

# Performance Data

Model 49-480 ■ 6mm Spacing ■ 3mm Bars ■ 0° Deflection

Free Area (m <sup>2</sup> ) Per Metre Length	Nominal Duct Width (mm)	Pressure Drop (Pa)	3	6	11	17	24	32	43	54	67
0.01	50	Flowrate per Length (l/s/m)	29	43	57	73	87	102	116	130	146
		NC Level	—	—	12	18	23	29	32	36	39
		Throw (m) Sill or Floor Side Wall	0.3 - 0.3 1.5 - 2.1	1.2 - 1.2 2.4 - 3.4	1.8 - 1.8 3.4 - 4.6	2.7 - 2.7 4.3 - 5.8	3.4 - 3.7 4.9 - 6.7	4.0 - 4.6 5.5 - 7.6	4.6 - 5.2 6.1 - 8.2	5.2 - 5.8 6.7 - 8.8	5.5 - 6.1 7.3 - 9.8
0.03	75	Flowrate per Length (l/s/m)	51	77	102	129	155	180	206	231	257
		NC Level	—	—	14	20	26	31	35	38	41
		Throw (m) Sill or Floor Side Wall	0.6 - 0.6 1.8 - 2.7	1.8 - 1.8 3.0 - 4.3	2.7 - 3.0 4.0 - 5.5	3.7 - 4.0 5.2 - 6.7	4.9 - 5.2 6.1 - 7.6	5.8 - 6.1 7.0 - 8.8	6.4 - 6.7 7.9 - 10.1	7.0 - 7.0 9.1 - 11.3	7.6 - 7.6 9.8 - 11.9
0.04	100	Flowrate per Length (l/s/m)	76	113	152	189	226	265	302	341	378
		NC Level	—	—	16	22	29	33	37	40	43
		Throw (m) Sill or Floor Side Wall	0.9 - 0.9 2.4 - 3.4	2.4 - 2.4 3.7 - 4.9	3.7 - 4.0 4.9 - 6.1	4.6 - 4.9 6.1 - 7.6	5.8 - 6.4 7.3 - 8.8	6.4 - 7.0 7.9 - 9.8	7.3 - 7.6 9.1 - 11.0	7.9 - 8.2 10.1 - 11.9	8.8 - 9.1 11.3 - 14.0
0.05	125	Flowrate per Length (l/s/m)	98	146	194	243	291	341	389	437	486
		NC Level	—	—	16	22	28	33	37	40	43
		Throw (m) Sill or Floor Side Wall	1.2 - 1.2 2.7 - 3.7	2.7 - 2.7 4.3 - 5.5	4.3 - 4.3 5.5 - 6.7	5.2 - 5.2 6.4 - 7.9	6.4 - 6.7 7.9 - 9.4	7.3 - 7.3 8.8 - 10.7	8.2 - 8.2 10.1 - 11.9	8.8 - 8.8 11.0 - 12.8	9.8 - 9.8 12.2 - 14.0
0.06	150	Flowrate per Length (l/s/m)	121	180	240	300	361	421	480	540	601
		NC Level	—	10	18	24	30	35	38	42	43
		Throw (m) Sill or Floor Side Wall	1.5 - 1.5 3.0 - 4.0	3.0 - 3.0 4.6 - 5.8	4.6 - 4.6 5.8 - 7.0	5.5 - 5.5 7.3 - 8.5	7.0 - 7.0 8.2 - 9.8	7.6 - 7.6 9.4 - 11.3	8.5 - 8.8 10.4 - 11.9	9.4 - 9.4 11.9 - 13.4	10.4 - 10.4 13.1 - 14.6

Model 49-481 ■ 6mm Spacing ■ 3mm Bars ■ 15° Deflection

Free Area (m <sup>2</sup> ) Per Metre Length	Nominal Duct Width (mm)	Pressure Drop (Pa)	3	6	12	19	27	37	49	62	76
0.01	50	Flowrate per Length (l/s/m)	31	45	60	76	91	107	121	136	152
		NC Level	—	12	20	27	32	37	41	44	47
		Throw (m) Sill or Floor Side Wall	0.3 - 0.3 1.5 - 2.1	1.2 - 1.2 2.4 - 3.4	1.8 - 1.8 3.4 - 4.6	2.7 - 2.7 4.3 - 5.8	3.4 - 3.7 4.9 - 6.7	4.0 - 4.6 5.5 - 7.6	4.9 - 5.5 6.1 - 8.2	5.2 - 5.8 6.7 - 8.8	5.5 - 6.1 7.3 - 9.8
0.02	75	Flowrate per Length (l/s/m)	51	76	102	127	152	178	203	229	254
		NC Level	—	12	20	27	32	37	41	44	47
		Throw (m) Sill or Floor Side Wall	0.6 - 0.6 1.8 - 2.7	1.8 - 1.8 3.0 - 4.0	2.7 - 2.7 4.0 - 5.2	3.7 - 4.0 4.9 - 6.4	4.6 - 4.9 6.1 - 7.6	5.5 - 5.8 6.7 - 8.5	6.4 - 6.7 7.9 - 9.8	6.7 - 7.0 8.5 - 10.7	7.0 - 7.3 9.4 - 11.9
0.04	100	Flowrate per Length (l/s/m)	73	108	146	181	217	254	290	341	362
		NC Level	—	13	21	28	34	38	42	45	48
		Throw (m) Sill or Floor Side Wall	0.9 - 0.9 2.1 - 3.0	2.7 - 2.7 3.7 - 4.6	3.7 - 3.7 4.9 - 6.1	4.6 - 4.6 5.8 - 7.3	5.8 - 6.1 7.0 - 8.5	6.4 - 6.7 7.9 - 9.8	7.3 - 7.6 8.8 - 10.7	7.6 - 7.9 9.8 - 11.9	8.5 - 8.5 11.0 - 12.8
0.05	125	Flowrate per Length (l/s/m)	94	141	187	235	282	328	376	424	471
		NC Level	—	14	22	29	34	39	43	46	49
		Throw (m) Sill or Floor Side Wall	0.9 - 0.9 2.7 - 3.7	2.7 - 2.7 4.0 - 5.2	4.0 - 4.0 5.5 - 6.7	4.9 - 5.2 6.4 - 7.9	6.1 - 6.4 7.6 - 9.1	7.0 - 7.3 8.5 - 10.4	7.6 - 7.9 9.4 - 11.3	8.5 - 8.5 10.4 - 12.2	9.4 - 9.4 11.6 - 13.4
0.06	150	Flowrate per Length (l/s/m)	115	172	231	288	345	403	461	519	576
		NC Level	—	14	22	30	35	40	43	47	50
		Throw (m) Sill or Floor Side Wall	1.2 - 1.2 3.0 - 4.0	3.0 - 3.0 4.3 - 5.5	4.3 - 4.3 5.8 - 7.0	5.5 - 5.5 7.0 - 8.2	6.7 - 6.7 8.2 - 9.4	7.6 - 7.6 9.1 - 10.7	8.5 - 8.5 10.1 - 11.9	9.1 - 9.1 11.3 - 12.8	9.8 - 9.8 12.2 - 13.7

